

COUNTRY OF DESTINATION: GB (ENGLAND)

Appliance model: 242FN5 nominal capacity of the burners : 4,00 - 291 g/ h (grams per hour)

Only competent installers using the correct materials, tools and equipment should install LPG systems.

Warning :please check the features of the model you have purchased !!

Please check the data plate of the cooker (The sticker with all relevant datas is placed on the back side of the cooker or under the cooker) and check that the model is the same as above indicated (see label above).

These instructions are valid for more models of appliances. Identify the product you have purchased.

PART A USER'S INSTRUCTIONS

Dear customer we thank you for purchasing this product.

We ask you therefore to carefully read this booklet before using the appliance.

These instructions must be carefully read and understood before use of the appliance.

Manufacturer n° 1004

A1 - description

The appliances are grouped according to several different categories from 1) to 13). Please check which group of appliances your appliance belongs to.

1) Cookers with oven

Model	number and type of hob burners	thermostat	grill			standard accessories
LT2	2 standard	no	no			oven tray, oven grid, pan clamps, gimbals, door catch, cooker gimballing lock, flame failure device
LT3	3 standard	no	no			oven tray, oven grid, pan clamps, gimbals, door catch, cooker gimballing lock, flame failure device

2) Cookers with oven, with thermostat

LT2L	2	yes	no			oven tray, oven grid, pan clamps, gimbals, door catch, cooker gimballing lock, flame failure device
LT2TOP	2	yes	no			oven tray, oven grid, pan clamps, gimbals, door catch, cooker gimballing lock, flame failure device
LT3L	3	yes	no			oven tray, oven grid, pan clamps, gimbals, door catch, cooker gimballing lock, flame failure device
LT3TOP	3	yes	no			oven tray, oven grid, pan clamps, gimbals, door catch, cooker gimballing lock, flame failure device
LT4TOP	4	yes	no			oven tray, grill trivet, pan clamps, gimbals, door catch, cooker gimballing lock, flame failure device

3) Cookers with oven, with thermostat, with grill inside the oven

LT2G	2 standard	yes	yes			oven tray, oven grid, pan clamps, gimbals, door catch, cooker gimballing lock, flame failure device
LT2GL	2	yes	yes			oven tray, oven grid, pan clamps, gimbals, door catch, cooker gimballing lock, flame failure device
LT2GTOP	2	yes	yes			oven tray, oven grid, pan clamps, gimbals, door catch, cooker gimballing lock, flame failure device
LT3G	3 standard	yes	yes			oven tray, oven grid, pan clamps, gimbals, door catch, cooker gimballing lock, flame failure device
LT3GL	3	yes	yes			oven tray, oven grid, pan clamps, gimbals, door catch, cooker gimballing lock, flame failure device
LT3GTOP	3	yes	yes			oven tray, oven grid, pan clamps, gimbals, door catch, cooker gimballing lock, flame failure device
LT4GTOP	4	yes	yes			oven tray, oven grid, pan clamps, gimbals, door catch, cooker gimballing lock, flame failure device

4) Cookers with oven, with separated grill

CGS92GN	2 standard	no	yes			oven tray, oven grid, pan clamps, gimbals, door catch, cooker gimballing lock, flame failure device
---------	---------------	----	-----	--	--	---

5) Cookers with oven, with thermostat, with separated grill

CGL92GN	2 standard	yes	yes			oven tray, oven grid, pan clamps, gimbals, door catch, cooker gimballing lock, flame failure device
---------	---------------	-----	-----	--	--	---

6) Compact cookers with oven

CGS92	2 standard	no	no			oven tray, oven grid, pan clamps, gimbals, door catch, cooker gimballing lock, flame failure device
-------	---------------	----	----	--	--	---

7) Compact cookers with oven, with thermostat

CGL92	2 standard	yes	yes			oven tray, oven grid, pan clamps, gimbals, door catch, cooker gimballing lock, flame failure device
-------	---------------	-----	-----	--	--	---

8) Built in ovens

CGS950	0	no	no			oven tray, oven grid, door catch, flame failure device
--------	---	----	----	--	--	--

9) Built in ovens with thermostat						
CGS2	0	yes	no			oven tray, oven grid, door catch, flame failure device

10) Built in ovens with thermostat, with grill inside the oven						
CGS2GL	0	yes	yes			oven tray, oven grid, door catch, flame failure device

11) Cookers						
242FN5	2 standard	no	no			flame failure device
312FA1	2 steel	no	no			flame failure device
31BFA1	1 steel	no	no			flame failure device
29B1FN4	1 standard	no	no			flame failure device
161FDV4	1 standard	no	no			flame failure device

12) Cookers with separated grill						
592FNT5	2 standard	no	yes			flame failure device grill tray grill grid

13) Built in hobs						
PGL02	2	no	no			flame failure device
PGL03	3	no	no			flame failure device
PGL04	4	no	no			flame failure device
PGS02	2 standard	no	no			flame failure device
PGS03	3 standard	no	no			flame failure device

This appliance is strictly for use with butane gas (G30) or propane gas (G31):

cat	Gas	G30	G31	destination country
I3+	p mbar	28-30	37	FR EE LV
I3+	p mbar	28-30	37	BE CY CH
I3+	p mbar	28-30	37	LT
I3+	p mbar	30	37	IT PT
I3+	p mbar	28	37	ES GB IE
I3+	p mbar	28	37	GR
I3B/P	p mbar	30	30	SK SI SE
I3B/P	p mbar	30	30	LV LT NO
I3B/P	p mbar	30	30	FI HU IS
I3B/P	p mbar	30	30	CZ DK EE
I3B/P	p mbar	30	30	MT NL CY
I3B/P	p mbar	50	50	AT DE CH

A2 - Installation

DANGER. Avoid asphyxiation. Provide ventilation when the stove is in use. Do not use for space heating. Do not cover. Do not use unattended.

(LPG = liquefied petroleum gas Propane, butane or a mixture of the two gases maintained in the liquid state by storage in cylinders under pressure).

The dangers associated with LPG systems when handled incorrectly include fire, explosion, burns and asphyxiation due to gas leakage from the system or accumulation of gas following flame failure in an appliance.

This appliance must be installed according to the current standards in practice in the country of destination and only by a competent person, that's to say a professional who is authorized by the manufacturer and who knows all the current standards in practice in the country of destination

The cleaning operations of the appliance must be done by a competent person.

It is recommended that a competent person explains the content of this booklet to ensure the operator is conversant with its operation

A3 - Gas cylinder

The gas cylinder must be replaced by a competent person who will install and connect the gas cylinder according to the current standards.

Warning: never obstruct the ventilation outlets of any gas cylinder compartment.

A4 - Flexible hose

The connection of this appliance can be done by means of a flexible hose and must be done according to the current standards in practice in the country of destination (the gas inlet is located at the rear side of the appliance or on the bottom of the appliance).

The hose must comply with the regulations of the country of destination

The gas hose must be checked regularly (often) and it must always be in perfect condition.

The gas hose must be changed before the expiry date by a competent person. Warning: in case of leakages do not try to repair the hose, do not use the appliance and contact immediately a competent person who will replace the hose.

The hose must be installed in such a way that it can be always inspected along all its length and so that it can be easily accessed for replacement.

Any connection to the gas supply should be made with tight mechanical connections and with normalized connections.

An optional gas connection kit could be supplied by the local importer. the kit must comply with the regulations of the country of destination.

A5 - Servicing and technical problems

Warning: no alterations or adjustments should be made by unskilled and unauthorized persons to the appliance. Do not remove any parts from the appliance or substitute alternatives as this may affect the safety of the appliance and can be very dangerous and is not permitted.

In the event of a failure or breakdown of a unit itself, turn off the gas supply at the cylinder (shut off the LPG supply at the cylinder valve) and contact a competent person

If you suspect that a control tap is faulty do not use the appliance, turn off the gas supply at the cylinder and contact a competent person

Warning: it is recommended that this appliance is professionally serviced every year to verify if the appliance is in perfect condition and for servicing if necessary (leakages, safety of operation, combustion quality, ventilation, safety and control devices) and in order to verify that the installation of the appliance still complies with the standards and regulations in practice.

A complete check-up of the whole installation has to be carried out punctually

~~We stress the importance of obtaining expert advice regarding the installation of LPG systems. We recommend that an inspection and test of such systems and associated alarm systems be carried out at least monthly to ensure their correct operation.~~ (LPG SYSTEM = System consisting of an arrangement of cylinder, safety devices, pressure regulators, connections, valves, piping, tubing, hoses, fittings, and devices intended to store, supply, monitor, or control the flow of fuel gas up to and including the appliance).

In the case of any deterioration, "regulator, rubber tube and tap" have to be replaced

In case of a gas leak, it is necessary to stop immediately all gas supply. Do not use naked light or operate any appliance which may cause a spark and ventilate the room and rooms next to the one where the appliance is installed, and above also the rooms which are at a lower level than the one where the appliance is installed.

LPG is heavier than air and any leakage will tend to fall to the bottom of a compartment. Gas may travel some distance like this and will form an explosive mixture with the air in the compartment. A spark as small as the static discharge from clothing may ignite such a mixture.

In conjunction with any LPG system the provision of an automatic gas detection and alarm system of a reliable type is strongly recommended and is required when an LPG appliance is installed in spaces below decks. It is essential that any electrical equipment associated with the gas detection and alarm system is certified as flame proof or intrinsically safe for the gas being used.

We stress the importance of installing a gas detector, a Carbon monoxide detector, Smoke and/or heat detector in each compartment containing LPG appliances.

A6 - Temperatures and ventilation

The importance of adequate ventilation for LPG appliances cannot be over emphasised. On no account is a ventilation system to be interfered with to prevent it functioning correctly. To do so may put persons at risk of carbon monoxide poisoning, asphyxiation or explosion.

Warning: some parts of the appliance become particularly hot when in operation (hob's grid, burners, fascia, front and rear parts of the appliance - in particular the oven flue outlet, door and door glass, pan holders) do not touch with bare hands the mentioned parts when the appliance is operated and after use till all the parts cool down.

It is recommended that an oven glove is used when the appliance is being used since hot parts could be touched by accident.

This appliance must be kept away from inflammable materials, and from heat sources of any kind.

This appliance and particularly the rear and bottom part must never be put in contact with plastic, wooden and inflammable objects and surfaces. do not use this appliance as a form of heating.

This appliance is not connected with combustion gases removal equipment.

Adequate ventilation (according to the regulations of the country of destination) must be provided to ensure the appliance works in a safe manner.

The ventilation openings must be opened before starting to operate the appliance and then kept open while the appliance is being used. The openings must not be blocked in any way (iso/dis 10239.3)

The necessary quantity of air is of 2000 liters per hour per each nominal kilowatt of capacity of the appliance.

Warning: the appliance must not be installed in areas subjected to strong draughts.

Ventilation, mechanical or natural, should not interfere with the flame pattern of an LPG appliance such that it may extinguish the flame or cause incomplete combustion of the gas.

Do not spray aerosols in the vicinity of this appliance.

Operating a gas cooking appliance brings about heat and damp exhaust in the room where it is being operated. always make sure that the room is being properly ventilated:

keep natural aeration apertures opened or install a mechanical aeration device (hood -power driven fan), an intensive and prolonged operation can require an extra aeration (by opening a window) or by providing a more efficient aeration (hood - if any - on full on position).

A7- Operating instructions

A7-1-

Do not leave the appliance in operation while unattended.

Check that all the control knobs (which are used to regulate the power of the burners through the gas taps) of the unit are on the closed (off) position before opening the cylinder valve (see here below in the text instructions concerning the gas taps and control knobs).

The control knobs are on the closed (off) position when the disc marked on the control knob coincides with the disc marked on the fascia

Do not open any burner (through the control knob/gas tap) or do not keep it open, without having a lighter ready to light the burner.

It is recommended that a spark ignition device is used rather than a match.

if your appliance is equipped with a piezo or electronic spark ignition, please see instructions.

Turn off the gas supply at the cylinder (shut off the LPG supply at the cylinder valve) when the appliance is not in operation and after use. The gas valve must be kept open only when the appliance is in use.

All burners are fitted with a flame failure safety shut off device (ffd). In the event of the flame being extinguished the gas supply will be cut off to the burner.

(FFD= Device that has a sensing element, activated by the presence or absence of a flame that causes the inlet of the LPG supply to a burner to be opened or closed)

Each control knob controls a burner of the appliance (opening, closing and power regulation of the burner). Your appliance is equipped with 1 or more front control knobs

Each control knob in installed on a gas tap which at its turn controls one single burner.

Warning: cookers with oven with thermostat and grill, built-in ovens with thermostat and grill (not valid for cookers with oven with separated grill): the grill and oven burners are controlled by the same tap / control knob (warning: the grill burner is an option).

In order to facilitate the selection of the correct burner the control knobs are clearly identifiable with respect to the burners they control by means of symbols on the fascia.

For each burner the closed (off), full on and reduced rate positions are marked by means of symbols on the fascia and on each control knob.

Appliances groups - see also above

1) cookers with oven
2) cookers with oven, with thermostat
3) cookers with oven, with thermostat, with grill inside the oven
4) cookers with oven, with separated grill
5) cookers with oven, with thermostat, with separated grill
6) compact cookers with oven
7) compact cookers with oven, with thermostat
8) built in ovens
9) built in ovens with thermostat
10) built in ovens with thermostat, with grill inside the oven
11) cookers
12) cookers with separated grill
13) built in hobs

A72- Hob burners

instructions valid for the following group of appliances:

- 1)cookers with oven
- 2)cookers with oven, with thermostat
- 3)cookers with oven, with thermostat, with grill inside the oven
- 4)cookers with oven, with separated grill
- 5)cookers with oven, with thermostat, with separated grill
- 6)compact cookers with oven
- 7)compact cookers with oven, with thermostat
- 11)cookers
- 12)cookers with separated grill
- 13)built in hobs

The closed (off) position is marked with a disc on the fascia above the control knob, the full on position is marked with a large flame and the reduced rate position is marked with a small flame. Each control knob is also marked with a disc

Any required setting between full on and reduced rate position can be obtained by positioning the control knob in such a way that the disc marked on the control knob is placed between these settings (large flame and small flame symbols) and not between large flame and disc symbols.

To resume:

closed burner = closed (off) position : the disc marked on the control knob is in coincidence with the disc marked on the fascia above the control knob.

burner at full rate = full on position : the disc marked on the control knob coincides with the large flame marked on the fascia

burner at reduced rate = reduced rate position : the disc marked on the control knob coincides with the small flame marked on the fascia

Warning : any accessory or pot must not hide the burners during the burners lighting operations.

Warning : always check that the control knobs are on the off position before opening the cylinder valve

A7-3- Oven and grill burners

Instructions valid for the following group of appliances:

- 2)cookers with oven, with thermostat
- 3)cookers with oven, with thermostat, with grill inside the oven
- 7)compact cookers with oven, with thermostat
- 9)built in ovens with thermostat
- 10)built in ovens with thermostat, with grill inside the oven

The oven and grill burners are controlled by the same control knob. Warning : the grill burner is an option

A disc (which identifies the closed - off - position) is marked on the fascia above the control knob.

The control knob is also marked with a disc

Starting from the closed (off) position, you can rotate the control knob anti-clockwise or clockwise. Warning : you can rotate the knob also clockwise starting from the closed (off) position only if the appliance is supplied with the optional grill burner

If you rotate the control knob anti-clockwise, you operate the oven burner, you can choose the desired temperature from "min" to 270°, for example when the disc marked on the control knob coincides with the reduced rate position symbol "min" marked on the fascia, you have selected the reduced rate position. So, any required setting between full on position and reduced rate position can be obtained by positioning the control knob in such a way that the disc marked on the control knob is placed between the "min" and 270° symbols marked on the fascia. Warning : do not position the control knob, in such a way that the disc marked on the control knob is placed between the "min" and the disc symbol (closed - off -position) marked on the fascia.

Appliance equipped with optional grill burner: if you rotate the control knob clockwise you operate the grill burner. There is only one setting, marked with the grill symbol on the fascia. Warning : do not position the control knob in such a way that the disc marked on the control knob is set between the grill symbol and the disc symbol (closed - off - position) marked on the fascia .

To resume:

Closed oven and grill burners = closed (off) position : the disc marked on the control knob is in coincidence with the disc marked on the fascia above the control knob.

Oven burner at full rate = full on position : the disc marked on the control knob coincides with the large flame marked on the fascia, or in the case of ovens with thermostat it coincides with the 270° symbol marked on the fascia

Oven burner at reduced rate = reduced rate position: the disc marked on the control knob coincides with the small flame marked on the fascia, or in the case of ovens with thermostat it coincides with the "min" symbol marked on the fascia

Grill burner = one possible setting only , the disc marked on the control knob coincides with the grill symbol marked on the fascia. so it is not possible to regulate the grill power.

Warning : always check that the control knobs are on the off position before opening the cylinder valve

A7-4- Oven and grill burners

Instructions valid for the following group of appliances:

- 5) cookers with oven, with thermostat, with separated grill
- 12) cookers with separated grill (Warning: this type of appliances are not equipped with an oven burner)

The oven and grill burners are controlled by two different control knobs

Oven burner:

A disc (which identifies the closed - off - position) is marked on the fascia above the control knob.

Starting from the closed (off) position, you can rotate the control knob anti-clockwise starting from the closed (off) position

If you rotate the control knob anti-clockwise, you operate the oven burner. You can choose the desired temperature from "min" to 270°, for example when the disc marked on the control knob coincides with the reduced rate position symbol "min" marked on the fascia, you have selected the reduced rate position, so, any required setting between full on position and reduced rate position can be obtained by positioning the control knob in such a way that the disc marked on the control knob is placed between the "min" and 270° symbols marked on the fascia. Warning : do not position the control knob, in such a way that the disc marked on the control knob is placed between the "min" and the disc symbol (closed - off -position) marked on the fascia.

To resume:

Closed oven burner = closed (off) position : the disc marked on the control knob is in coincidence with the disc marked on the fascia above the control knob.

Oven burner at full rate = full on position : the disc marked on the control knob coincides with the large flame marked on the fascia, or in the case of ovens with thermostat it coincides with the 270° symbol marked on the fascia

Oven burner at reduced rate = reduced rate position : the disc marked on the control knob coincides with the small flame marked on the fascia, or in the case of ovens with thermostat it coincides with the "min" symbol marked on the fascia

Grill burner:

The closed (off) position is marked with a disc on the fascia above the control knob, the full on position is marked with a large flame and the reduced rate position is marked with a small flame, each control knob is also marked with a disc

Any required setting between full on and reduced rate position can be obtained by positioning the control knob in such a way that the disc marked on the control knob is placed between these settings (large flame and small flame symbols) and not between large flame and disc symbols.

To resume:

Closed grill burner = closed (off) position : the disc marked on the control knob is in coincidence with the disc marked on the fascia above the control knob.

Grill burner at full rate = full on position : the disc marked on the control knob coincides with the large flame marked on the fascia

Grill burner at reduced rate = reduced rate position : the disc marked on the control knob coincides with the small flame marked on the fascia

Warning : always check that the control knobs are on the off position before opening the cylinder valve

A7-5- Oven and grill burners

instructions valid for the following group of appliances:

- 1)cookers with oven
- 4)cookers with oven, with separated grill
- 6)compact cookers with oven
- 8)built in ovens

The closed (off) position is marked with a disc on the fascia above the control knob, the full on position is marked with a large flame and the reduced rate position is marked with a small flame, each control knob is also marked with a disc

Any required setting between full on and reduced rate position can be obtained by positioning the control knob in such a way that the disc marked on the control knob is placed between these settings (large flame and small flame symbols) and not between large flame and disc symbols.

To resume:

Closed burner = closed (off) position : the disc marked on the control knob is in coincidence with the disc marked on the fascia above the control knob.

Burner at full rate = full on position : the disc marked on the control knob coincides with the large flame marked on the fascia

Burner at reduced rate = reduced rate position : the disc marked on the control knob coincides with the small flame marked on the fascia

Warning : always check that the control knobs are on the off position before opening the cylinder valve

A7-6- To light and operate the hob burners

instructions valid for the following group of appliances:

- 1)cookers with oven
- 2)cookers with oven, with thermostat
- 3)cookers with oven ,with thermostat, with grill inside the oven
- 4)cookers with oven, with separated grill
- 5)cookers with oven ,with thermostat, with separated grill
- 6)compact cookers with oven
- 7)compact cookers with oven, with thermostat
- 11)cookers
- 12)cookers with separated grill
- 13)built in hobs

Choose the burner that better suits the pan chosen for cooking

Open the cylinder valve

Place a lighter to the selected burner

If the appliance is equipped with a piezo or electronic spark ignition, you must press the plastic button identified by a spark symbol on the fascia.

Simultaneously push in and rotate the control knob anti-clockwise to the full on position, that's to say till the disc marked on the control knob coincides with the large flame symbol marked on the fascia next to the knob.

Light the burner

After the burner has been lit, keep the control knob pushed for 10-20 seconds in order to unlock the safety thermocouple (ffd) (see drawing)

Release the control knob

If the burner goes out when the control knob is released, rotate the control knob clockwise to the off position (full disc symbol) and repeat the above lighting procedure (see instructions to turn off the burner)

To reduce the flame of the burner , rotate the control knob anti-clockwise towards the reduced rate position, that's to say till the disc marked on the control knob coincides with the small flame symbol marked on the fascia

To turn off the burner , rotate the control knob clockwise until you reach the off position (disc symbol vertically above the control knob), that's to say till the disc marked on the control knob coincides with disc marked on the fascia above the control knob.

Beware: the pan must be centered on the burner to be used and should have the following sizes:

burners 2,3 - 3,0 kw min/max pan diameter : 140/200 mm

burners 1,7 kw min/max pan diameter : 120/180 mm

burners 0,9 - 1,0 kw min/max pan diameter : 100/140 mm

A7-7- To light and operate the oven burner

instructions valid for the following group of appliances:

- 1)cookers with oven
- 2)cookers with oven, with thermostat
- 3)cookers with oven, with thermostat, with grill inside the oven
- 4)cookers with oven with separated grill
- 5)cookers with oven, with thermostat, with separated grill
- 6)compact cookers with oven
- 7)compact cookers with oven, with thermostat
- 8)built in ovens
- 9)built in ovens with thermostat
- 10)built in ovens with thermostat, with grill inside the oven

Warning in case the appliance is equipped with a piezo or electronic spark ignition, never light the burner with the door closed.

Open the oven door completely, to the full open position -(position 2) - (for the door opening operations, see also "oven door -door safety lock - heating protection plate and attached drawing)

Before starting the lighting procedures remove the oven accessories (oven grid and oven tray: warning some models are equipped with two trays , only the upper one must be removed !) and wipe off with a damp cloth.

Open the cylinder valve

Use the control knob identified by the oven symbol marked on the fascia (in some models the same control knob controls both the grill and the oven burners).

Place a lighter to the oven burner

If the appliance is equipped with a piezo or electronic spark ignition, you must press the plastic button identified by a spark symbol on the fascia.

simultaneously push in and rotate the control knob anti-clockwise to the full on position, that's to say till the disc marked on the control knob coincides with the 270° symbol marked on the fascia next to the knob (in case the appliance is not equipped with thermostat push in and rotate the control knob anti-clockwise to the full on position, that's to say till the disc marked on the control knob coincides with the large flame symbol marked on the fascia next to the knob).

Light the burner

After the burner has been lit, keep the control knob pushed for 10-20 seconds in order to unlock the safety thermocouple (ffd) (see attached drawing)

Release the control knob

If the burner goes out when the control knob is released, rotate the control knob clockwise to the off position (full disc symbol) and repeat the above lighting procedure (see instructions to turn off the burner)

To reduce the flame of the burner , rotate the control knob towards the position of desired temperature, that's to say till the disc marked on the control knob coincides with the desired temperature symbol or the reduced rate symbol "min" marked on the fascia. (in case the appliance is not equipped with thermostat rotate the control knob anti-clockwise towards the reduced rate position, that's to say till the disc marked on the control knob coincides with the small flame symbol marked on the fascia).

To turn off the burner , rotate the control knob clockwise until you reach the off position (disc symbol vertically above the control knob), that's to say till the disc marked on the control knob coincides with disc marked on the fascia above the control knob.

Warning: before closing the oven's door ,be sure that the burner is lit . You can check the burner operation also through the glass panel of the door.

It is recommended to let the oven warm up for 1 mn before closing the door .

The door must be closed gently in order to avoid putting the flame out (and the burner off).

The door must be kept closed while you are using the oven to cook

Warning: if aluminium foil is used in the oven, then it must not be allowed to block the oven flue outlet or smother the burner

A7-8- To light and operate the grill burner

instructions valid for the following group of appliances:

- 3)cookers with oven, with thermostat, with grill inside the oven
- 10)built in ovens with thermostat, with grill inside the oven

Warning: the grill burner must not be used when the other burners(hob burners in the case of cookers with oven) of the appliance are in operation .

In case the appliance is equipped with a piezo or electronic spark ignition, never light the burner with the door closed.

The oven door must be opened completely (position 2) in the case of lighting the optional grill burner.

Open the oven door.

In order to open the oven door press the door safety lock and then pull the door till the full open position (positions 2) is reached in order to start the lighting procedures.

Extract the heating protection plate .

Warning the door must be completely open (position 2) before starting the lighting procedures.

Before starting the lighting procedures remove the oven accessories (oven grid and oven tray: warning there are two trays in some models , only the upper one must be removed !) and wipe off any marks with a damp cloth.

Open the cylinder valve

Place a lighter to the grill burner

Use the control knob identified with the grill symbol marked on the fascia (the same control knob controls both the oven and the grill burners in some models).

If the appliance is equipped with a piezo or electronic spark ignition, you must press the plastic button identified by a spark symbol on the fascia.

Simultaneously push in and rotate the control knob clockwise to the full on position, that's to say till the disc marked on the control knob coincides with the grill symbol marked on the fascia next to the knob, warning only one setting is possible.

Light the burner

After the burner has been lit, keep the control knob pushed for 10-20 seconds in order to unlock the safety thermocouple (ffd) (see attached drawing)

Release the control knob

If the burner goes out when the control knob is released, rotate the control knob anti-clockwise to the off position (full disc symbol) and repeat the above lighting procedure (see instructions to turn off the burner)

To turn off the burner , rotate the control knob anti-clockwise until you reach the off position (disc symbol vertically above the control knob), that's to say till the disc marked on the control knob coincides with disc marked on the fascia above the control knob.

Warning: after lighting the grill burner the oven door must be kept partially opened (the oven door can be opened in two different positions: position 1=door partially opened; position 2= door completely open) .

After having opened completely the door (position 2) as described above for the lighting operations, now close the door gently (in order to avoid to put the flame out and the burner off) until the partial opening position (position 1) and the heating protection plate is reached. (the heating protection plate has been previously extracted as above described).

Once in this position, the door must be locked to the protection plate .

A7- 9 - To light and operate the grill burner

instructions valid for the following group of appliances:

- 5)cookers with oven, with thermostat, with separated grill
- 4)cookers with oven, with separated grill
- 12)cookers with separated grill

The grill burner must not be used when the other burners (hob burners and the oven burner in case the cooker is supplied with oven) of the appliance are in operation

Remove the grill accessories (grill trivet and tray)

Open the cylinder valve

Place a lighter to the grill burner

If the appliance is equipped with a piezo or electronic spark ignition, you must press the plastic button identified by a spark symbol on the fascia.

Simultaneously push in and rotate the control knob anti-clockwise to the full on position, that's to say till the disc marked on the control knob coincides with the large flame symbol marked on the fascia next to the knob.

Light the burner

After the burner has been lit, keep the control knob pushed for 10-20 seconds in order to unlock the safety thermocouple (ffd) (see attached drawing)

Release the control knob

if the burner goes out when the control knob is released, rotate the control knob clockwise to the off position (full disc symbol) and repeat the above lighting procedure (see instructions to turn off the burner)

To reduce the flame of the burner , rotate the control knob anti-clockwise towards the reduced rate position, that's to say till the disc marked on the control knob coincides with the small flame symbol marked on the fascia

To turn off the burner , rotate the control knob clockwise until you reach the off position (disc symbol vertically above the control knob), that's to say till the disc marked on the control knob coincides with disc marked on the fascia above the control knob.

Warning : after lighting the grill burner, the grill tray and trivet must be placed correctly under the grill burner to protect the grill base when the grill burner is in operation.

Be sure not to block the flue outlet on the hob (special opening on the hob)

A8 - How best to use the oven

A8-1 - Clean the oven interiors completely (oven sides, oven grid, oven trays, oven door).

Allow the oven to heat for 2 hours before using it for the first time , in order to expel any smells before the introduction of food.

The oven must be pre-heated for approximately 10 minutes before introducing the food

During cooking , adjust the temperature with the oven control knob , according to what is needed. we can expect a maximum temperature of approximately 250 - 270°C. (see above instructions)

A8- 2 - Oven trivet and baking tray

the oven shelf and baking tray must be fitted correctly through the guides. (see attached drawing)

A8- 3 - Oven's door - door safety lock - heating protection plate (The heating protection plate is installed only on appliances equipped with grill burner inside the oven)

The oven's door is supplied with an automatic locking device on the upper part, that's to say a lever which must be used to lock the door .

The door can be opened in 2 different positions (position 1 - door partially open; position 2 = door completely open) .

Heat protections plate. Only the following appliance are equipped with heat protection plate:

- cookers with oven, with thermostat,with grill inside the oven
- built in ovens with thermostat,grill inside the oven

On the upper part of the oven there is a heating protection plate which can slide outward, which should be used to protect the knobs from the heat when the door is partially opened (position 1) and the grill is functioning, or when the door is fully opened after functioning and the oven is hot .

If the heating protection plate is not used the control knobs would become too hot because the heat would go direct on to them .

In order to open the door it is necessary to press the door safety lock .

To resume, the door can be placed in 3 positions:

Position 1: door partially open. the door must be in this position when the grill is used.

Position 2: door completely open. the door must in this position :

- for the lighting procedure of the grill burner
- for the lighting procedure of the oven burner
- when you must introduce inside the oven or extract from the oven accessories (grid, tray)
- when you must introduce inside the oven food or extract food from the oven

Position 3: door closed

Warning: the door must be in position 2 when the grill and oven burners must be lit in case the appliance is equipped with a piezo or electronic spark ignition

After having closed the door (position 3) the door safety lock will automatically lock the door to the oven, for safety reasons it can be easily checked if the door safety lock is working properly: after having closed the door , pull the door. if the door safety lock works properly you cannot open the door unless you previously press the door safety lock .

A8-4 - Cooker gimbaling safety system (optional) :

When the cooker is not in use the bolt placed on the right front of the appliance must be closed. (the system is placed on the lower front part of the appliance on the right

A9 - How to use the accessories

A9-1 - Pan clamps and fiddle rails' use (optional) (see attached drawing)

A pan clamps system is installed or can be installed on some models of appliances.

The pan clamps system with rail is placed on the upper front side of the appliance on the pan support.

Following attached drawing, insert the clamps on the rail (in case they are not already installed) in the front of the appliance. move the clamps sideways according to the dimension of the pans. Make sure that the pan is in the centre of the burner to be used.

In order to stop the clamps in the chosen position, turn the knobs clockwise, anticlockwise for unlocking them

A9-2- Gimbals regulators - available for certain models only (optional)

The appliance could be equipped with a patented system which permits to regulate the position of the appliance in respect of the gimbals to have the appliance always well balanced.

to regulate the position of the appliance, you just have to turn at the same time the 2 knobs placed on the highest part of the cooker sides (there is one knob on the left front side and one knob on the right front side), you can turn the knobs clockwise or anti-clockwise. By doing this operation you will regulate the position of the appliance in respect of the gimbals axis. You can turn the knobs till you see that the cooker is perfectly balanced. This device is particularly helpful when more pans must be placed at the same time inside on the hob's grid, or when it is necessary to keep the door partially open to use the oven grill (door in position 1) such operations lead in fact to a movement of the barycenter of the appliance.

A9-3- Battery operated ignition (optional)

The battery is placed on the back or on the front side of the appliance inside a special plastic container. Unscrew the container's cap to substitute the battery.

In some cases the battery is directly placed under the button itself, which must be unscrewed to have access to the battery

A10 - Cleaning

It is recommended to contact a competent person if the user is unskilled.

After use, and before carrying out the cleaning of the appliance wait for it to cool down.

Before starting the cleaning operations close the cylinder valve. (shut off the LPG supply at the cylinder valve)

Clean the appliance regularly and carefully.

Cleaning of the burners: use a damp sponge added with soap or with appropriate detergent, if the holes of the burners or the venturi are blocked, never use metallic objects which could modify the diameter of the holes, producing a bad functioning of the appliance. please contact a competent person!

Do not allow spillages or other materials enter the holes of the burners and the appliance interiors.

Clean the appliance every time after use. avoid acid or alkaline substances (lemon juice, vinegar, etc...) or dirt, which could spoil the surfaces.

Stainless steel surfaces must be cleaned with a damp cloth and special dedicated products.

Enamelled surfaces must be cleaned with a damp cloth and special dedicated products.

Do not use abrasive cleaners.

In case the appliance has not been used for a long time, verify that the burners are clean and contact a competent person who will check if the appliance is in perfect condition.

Warning: children should be kept away from the appliance.

PART B INSTALLATION INSTRUCTIONS

for the professional (competent person) only

Only competent installers using the correct materials, tools and equipment should install LPG systems.

LPG systems should be checked for leakage, general condition and correct operation at least monthly.

Ventilation systems should be checked for leakage, general condition, obstructions and correct operation at least monthly.

LPG leakage alarms, carbon monoxide alarms and smoke detectors should be tested at least monthly for correct operation.

LPG systems should be serviced by a competent person at least annually. The servicing should be such as to ensure that the system maintains compliance with the provisions and advice of the current gas safety regulations and standards in practice in the country of destination.

- The consumer must become familiar with the appliance according to the present instructions booklet. The professional who installs the appliance must hand the present booklet to the consumer
- Appliances shall be installed away from flammable materials and having regard to inadvertent contact of persons and materials with hot surfaces.
- Warning: legal requirements for installation and maintenance: this appliance must be installed and maintained by a competent person in accordance with the current gas safety regulations and standards in practice in the country of destination.
- Warning: in case some parts of the appliance are replaced for servicing (only if authorized by the manufacturer), the appliance must be re-tested (if necessary by the manufacturer) to verify that the appliance is in perfect condition (leakages, safety of operation, combustion quality, ventilation, safety and control devices)
- The competent person must be authorized by the manufacturer

Installation and maintenance of this appliance have to be carried out by a skilled person in accordance with the relevant Regulations, in particular:

- The user has to comply with technical and safety rules prescriptions concerning use of inflammable gas and liquified hydrocarbons in houses and outbuildings, stipulating that no unit should be installed in any room unless:
 - a sufficient air inlet and outlet
 - a minimum volume of 8 m³
 - a window with a minimum opening area of 0,40 m² - a minimum height of 0,30 m from the ground are provided
- installation and use of the appliance must be in compliance with the sanitary regulations, with gas installations on board
- installation must be in compliance with the guideline 94/25/ce from european parliament and council dated june 16th, 1994 concerning the comparing of legislative, statutory and administrative stipulations of member states as to pleasure boats and with iso 10239 and with iso/dis 9094-1.2
- Gas cylinders of 3 kg or more must be used
- Gas regulators, hoses, and any other connection device used for the installation of this appliance must be in accordance to the current standards in practice in the country of destination.
- Change the gas cylinder away from fire or sources of heat
- The minimum distance between the gas cylinder and the appliance must be of 0,4 metres
- The gas hose must be according to the current standards in practice in the country of destination of the appliance and it must be installed according to the regulations and standards in practice in the country of destination
- The maximum length of the flexible hose must be of the minimum practicable length and should not exceed 1,0 metres
- Do not allow the hose to come into contact with any part of the appliance except the gas inlet located at the rear side of the appliance or under the appliance
- Never allow the hose to come into contact with the back panel and flue outlet of the oven (appliances equipped with oven). The hose must be kept away from the flames of the burners (appliances equipped with hob burners), and the exhaust fumes coming out from the flue outlet (appliances equipped with oven) and it must not cross the back side of the appliance (see attached drawing).
- The flexible hose must extend along all its length and it must not be entangled or twisted and it must be installed so that even if the appliance is tilted it will not be subject to any kind of distortion (please carefully check that the hose extends without efforts and that the hose itself, the appliance gas connection or a any other gas part are not stressed in case of gimbaled appliances).
- The gas hose must be replaced before the expiry date
- Do not force the gas connection inlet of the cooker or any other part of the appliance when installing the hose.

- The hose must be installed in such a way that it can be always inspected along all its length and so that it can be easily reached for replacement.
- Once installed the gas connection should be tested for any gas leakage. do ensure that the area is well ventilated and do not test for a long period.
- Warning: never use a flame to test the soundness of the gas circuit
- Tightness control: testing process in accordance with norm iso/dis 10239.3 paragraph 10). Before putting the whole installation into service with lpg supply, always make sure that setting-up has been carried out properly (from the regulator up to the burners in shut-off position). The shut-off valves being opened, test the whole installation - before fixing the regulator on the rubber tube- with an air pressure equal to three times service pressure but testing pressure shall never exceed 150 mbar. The whole connection has to be considered as tight if after a five-minute period (this should enable pressure to get balanced), pressure remains constant +/- 5 mbar during the 15 following minutes. An appropriate liquid, such as a soapy water, can be used to detect any possible leakage on the connection part. After having tested pressure on the whole installation, every single connected appliance - including burners ffd - has to be tested while functioning. A visual control of the flame height on the burners has to be carried out while all burners are being operated in order make sure the service pressure is suitable for each appliance.
- Warning: do not use any detergent liable to contain ammoniac: this would damage brass connection parts. Although the damage could not be obvious at the beginning, fissures and leakage can appear a few months later.
- Setting -up: regulator and flexible tube
 - Special "boat regulator:" must be used.
 - Always make sure that the rubber seal at the regulator inlet connection is properly set and in good condition
 - Screw and tighten the regulator wing-nut on the gas cylinder or on the special tap fitted on 3 kg gas cylinders or on the "clip-on" device for 6 kg gas cylinders
 - A complete check-up of the whole installation has to be carried out punctually
 - In the case of any deterioration, " regulator, rubber tube and tap" have to be replaced
- This appliance must be kept away from inflammable materials , and the partitions and furniture next to the appliance must be heat resistant and not inflammable, the surface / furniture on which the appliance is installed must be able to resist at least a +100°C temperature.
- In order to obtain the best utilization it is necessary to assure a good circulation of air around the appliance (in particular the rear and back side of the appliance must be well ventilated). It has to be installed only in situation of effective ventilation (but do not install the appliance in areas subjected to strong draughts) according to the local regulations. (drawing n.1)
- There should be no obstruction above the hob burners for a minimum height of 500 mm
- If the appliance is fitted into a recess or built into a unit an air gap of 100 mm must be kept at each side or even more (see also drawings).
- The appliance must not be installed in an inclined plane
- Warning: the appliance must be installed in a safe and stable manner
- The quantity of air necessary for the combustion is approximately 2 cubic meters for each nominal kw produced by the burners

Emergency Action

A notice detailing the action to be taken when a gas leak is detected, or a fault with the system is discovered, should be prominently displayed on board the vessel. The notice should include at least the following:

The need to be alert for gas leakage.

The action to be taken in the event of gas leakage being discovered.

The use and location of fire extinguishing equipment on board the vessel.

Any appliance instructions relating to the safe operation of appliances.

The location of shut off valves.

The need to extinguish all flames, cigarettes and not to operate any electrical or other equipment which may induce a spark.

- The appliance and the burners have been designed and built in order to be used with following injectors and with the following input (see attached schema or the label applied at the beginning of the present instructions booklet):

BUTANE G30 28...30 MBAR

COOKER MODEL	BIG BURNER			MEDIUM BURNER		
	JET Ø mm	Max kW	Min kW	JET Ø mm	Max kW	Min kW
242FN5	0,75	2,30	0,65	0,65	1,70	0,50

Warning: if using the gimbaling system (drawing n.1) , ensure the bulkhead is of sufficient strength to hold the weight of the unit

The appliance must be installed in a cabinet similar to the one of the enclosed drawings - warning: a minimum clearance at each side of the appliance must be kept, in addition ensure that no obstruction to the appliance's air flow is permitted at the base, sides and back and upper side.

If available use the special optional plates which must be fixed on each side of the appliance on the lower part with the preexisting screws.

Warning : use non-combustible material for the surround - such as steel sheet

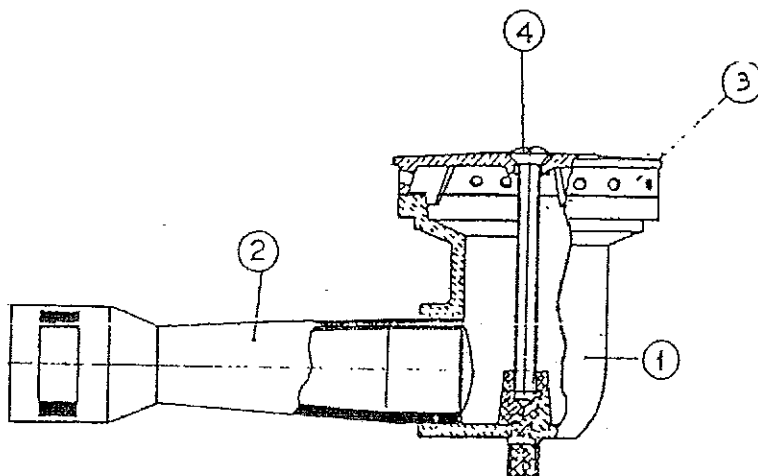

- 1 - Burner body
- 2 - venturi tube
- 3 - Brass Flame Spreader
- 4 - Screw

Cleaning of the burners: use a damp sponge added with soap or with appropriate detergent, if the holes of the burners or the venturi are blocked , never use metallic objects which could modify the diameter of the holes ,producing a bad functioning of the appliance. please contact a competent person! Do not allow spillages or other materials enter the holes of the burners and the appliance interiors.

DRAWING N.1

